



KV 8091/92 4x4 Pocket Door™ Slide

POCKET DOOR SLIDES

- 75 lb. class
- rack & pinion system



The Knappe & Vogt 4x4 Pocket Door™ Slide is ideal for use in large entertainment and home theater cabinets. It is specially designed to hold over-size doors up to 75 pounds and 72



inches in height. The 4x4 Pocket Door Slide's dual rack and pinion system virtually eliminates door sag, speeding installation, minimizing adjustment and eliminating callbacks. As with all Knappe & Vogt drawer slides, the 4x4 Pocket Door™ Slide is designed to meet or exceed ANSI performance standards as established by BIFMA, BHMA and KCMA.

KEY PRODUCT FEATURES

- *Dual rack and pinion system virtually eliminates door sag.*
- *75-Pound Class rated for heavy-duty applications.*
- *Maximum door dimensions: 72" h x 26" w*
- *Innovative indexing pin allows door slide to nest within door rack for easy alignment and installation.*
- *Self-closing, three-way adjustable isometric door hinge.*
- *Hinge bases are pre-mounted on the 8092 for faster installation.*
- *8091 allows installer to use the hinge/hinge base of their choice.*
- *Precision steel ball bearings provide smooth and quiet operation.*
- *Backed by the exclusive Knappe & Vogt Limited Lifetime Warranty.*

DIMENSIONS

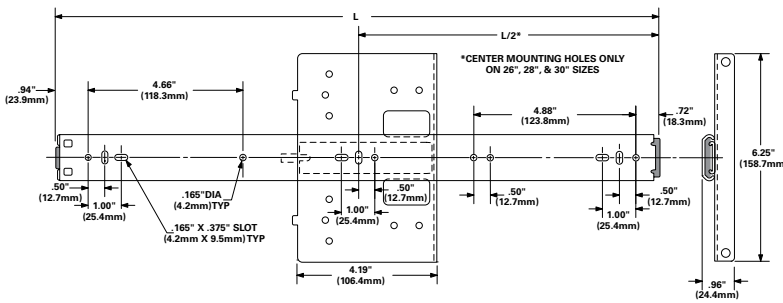

Size	L	L/2*	Approx. Door Conceal**	Approx. Cabinet Depth***
12"	12-1/8"	—	8"	12-3/8"
13"	13-18"	—	9"	13-3/8"
14"	14-1/8"	—	10"	14-3/8"
15"	15-1/8"	—	11"	15-3/8"
16"	16-1/8"	—	12"	16-3/8"
18"	18-1/8"	—	14"	18-3/8"
20"	20-1/8"	—	16"	20-3/8"
22"	22-1/8"	—	18"	22-3/8"
24"	24-1/8"	—	20"	24-3/8"
26"	26-1/8"	13-1/16"	22"	26-3/8"
28"	28-1/8"	14-1/16"	24"	28-3/8"
30"	30-1/8"	15-1/16"	26"	30-3/8"

* Center mounting holes only on 26", 28", & 30" sizes
 ** Door fully retracted into case
 *** Add thickness of door to determine minimum

INSTALLATION

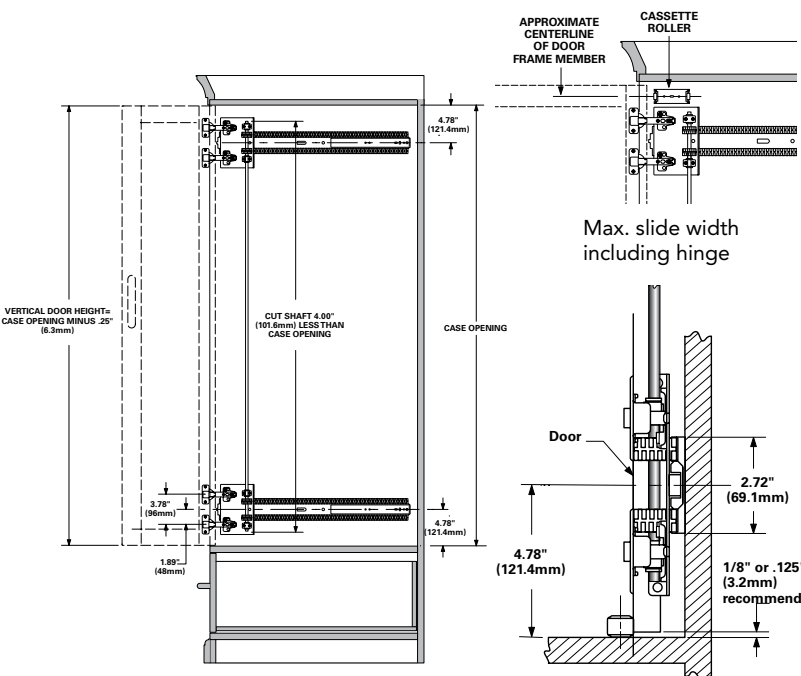

NOTE: Not recommended for square doors or where door width is greater than door height.

Hinge Options	Hinge Description	Door Thickness	Edge Bore* Distance	Hinge Cup Bore Dia.	Hinge Cup Bore Depth	Max. Slide Width, including hinge, for Partition Installations	Partial Overlay
8080	Standard Hinge	3/4" [19mm]	1/4" [6mm]	1-38" [35mm]	11.8mm	1-25/32" [45.2mm]	N/A
8080FS	Standard Hinge w/ Free Swing Knuckle	3/4" [19mm]	1/4" [6mm]	1-3/8" [35mm]	11.8mm	1-25/32" [45.2mm]	N/A
8080L	Overlay Door	3/4" [19mm]	3/8" [9.5mm]	1-37/64" [40mm]	13.2mm	1-25/32" [45.2mm]	1/4" [6.3mm]
8085	Thick Door	1" [25.4mm]	5/16" [8mm]	1-37/64" [40mm]	13.2mm	2-5/32" [54.8mm]	N/A
8086	Extra Thick Door	1-1/4" [32mm]	1/2" [12.7mm]	1-37/64" [40mm]	13.2mm	2-15/32" [61.9mm]	N/A

*Edge bore distances shown are approximate. Always bore a test block to verify hinge cup locations.

SPECIFICATIONS

- name** 8091/92 4x4 Pocket Door™ Slide
- mounting** Mounts directly to cabinet side.
- load rating** 75-Pound Class
- max. door dimensions** 72"h x 26"w
- finish** Ebony Black (EB)
- action** Progressive movement on precision steel ball bearings.
- additional features**
 - Rack and pinion design virtually eliminates door sag.
 - Slide rack indexing system speeds installation time.
 - Metal ball retainer holds three bearings per inch of race for smooth and quiet operation.
 - Multiple hinge options allow for a wide variety of applications.
- sizes** 8092: 12", 13", 14", 15", 16", 18", 20", 22", 24", 26", 28" and 30".
 8091: 12", 13", 14", 15", 16", 18", 20", 22", 24", 26", 28" and 30".
- packaged** Poly Pack (8092P): 1 set per poly pack w/screws and instructions. Model comes with attached hinge bases. Hinges and pinion shafts must be ordered separately

Poly Pack (8091P): 1 set per poly pack w/screws and instructions. Shafts must be ordered separately. Hinges and hinge bases supplied by installer.

ordering information

Slides: 8092P EB 12, 13, 14, 15, 16, and 18-30"
 8091P EB 12, 13, 14, 15, 16, and 18-30"

Shafts:			Packed
8092SB	EB 36"	1 pair	
8092SB	EB 48"	1 pair	
8092SB	EB 72"	1 pair	
8090B	EB 36"	10 each	
8090B	EB 48"	10 each	
8090B	EB 72"	10 each	

	Hinge Kits	Hinge Pack
	(2 hinges w/screws)	(40 hinges w/o screws)
Standard:	8080 HKEZSEB	8080 HPEZSEB
Free-Swing:	8080 HKEZFEB	8080 HPEZFEB
Overlay Dr.:	8080 HKEZLEB	8080 HPEZLEB
Thick Dr.:	8085 HKEZTEB	8085 HPEZTEB
Ex. Thick Dr.:	8086 HKEZXEB	8086 HPEZXEB

Raised Panel Door Roller: 8090P CR (1 each w/screws)

NOTE: Consult price list or KV Customer Service for stock availability information on different sizes, packages and finishes.

The 4x4 Pocket Door™ Slide is designed to be mounted to the side of a cabinet for pocket door wood applications in the 75-pound class. Not recommended for receding or flipper door applications.

Knape & Vogt reserves the right to change product specifications at any time without notice and without incurring responsibility for existing units.